

**BASCO® TYPE ES  
INSTALLATION &  
MAINTENANCE  
GUIDE**

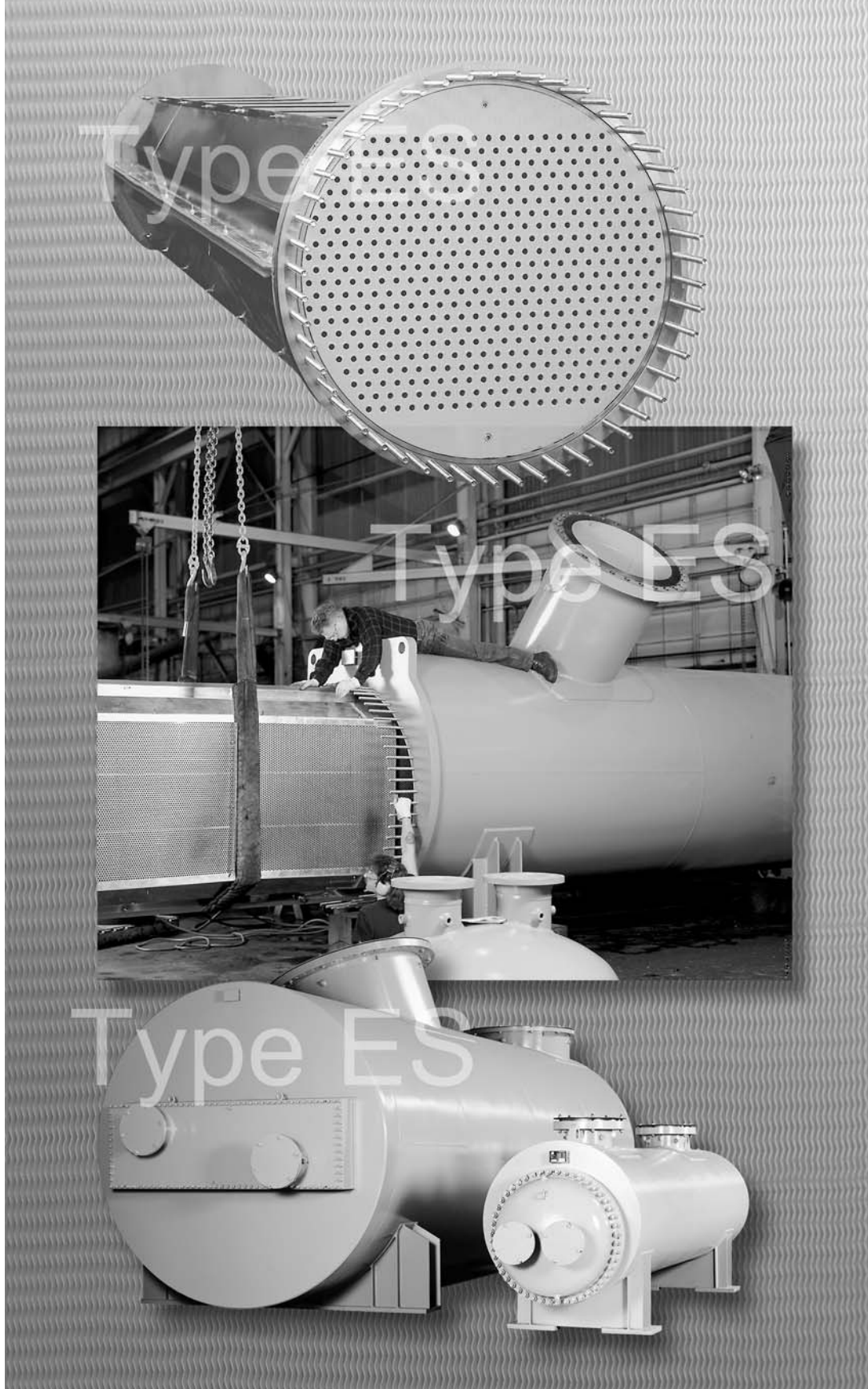

**API Heat Transfer**

*...world leaders in heat transfer technology*

# INSTALLATION AND OPERATIONAL PROCEDURES FOR BASCO "ES" HEAT EXCHANGERS

## INSTALLATION

**SITE SELECTION** is the first step to insure proper installation of Basco heat transfer equipment. It is important that the heat exchanger is easily accessible for inspection, maintenance and cleaning.

**Straight Tube** heat exchangers (removable bundles)-allow for sufficient clearance at the stationary end for removal of the bundle from the shell and provide adequate space beyond the floating end to accommodate removal of the shell cover and/or floating head cover.

**FOUNDATIONS** must be sufficiently robust as to provide permanent support without settling and to absorb any normal vibrations from outside causes.

Basco Type ES heat exchangers are equipped with cradles for horizontal installation. When the cradles are welded, the foundation bolts at the floating end should be loose to allow free expansion and contraction of the shell.

The exchanger must be set level and square so pipe connections can be made without forcing and to reduce the possibility of leaks during operation.

**INSPECT** all exchanger openings for foreign material before installation. The entire system should be clean before starting operation. **Do not** remove protective plugs and covers until just prior to installation.

Pieces of gaskets, metal clips, scale and similar materials can plug tubes. To minimize the risk of blockage, take the following precautions:

- Use care in placing gaskets.
- Do not use valves with soft seats.
- Blow-out pipelines before connecting to the unit.

**FITTINGS AND PIPING** are critical in the proper installation of API Heat Transfer equipment. To insure the full rated capacity of the unit it is important to select the proper pipe sizes. While pipe connections for average conditions are specified on certified drawings, further thought must be given to plant conditions-such as length of pipes, fittings, obstructions, and the allowable pressure drop through the heat exchanger.

**By-Pass Valves** should be provided in both circuits of the unit to permit periodic inspection or repair without interruption of the fluid flow.

**Test Connections** for thermometer well and pressure gauges, when not integral with the exchanger nozzles, should be installed close to the exchanger in the inlet and outlet piping.

**Vent valves** should be provided to prevent gas binding of the heat transfer surface and a subsequent reduction in thermal capacity in condensing units.

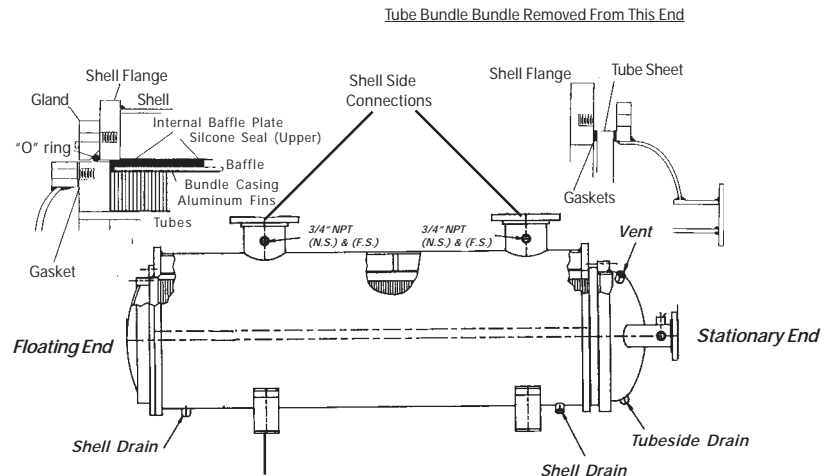

NOTE: Connect a trap to the "cold" side drain for condensing service. Refer to the general arrangement drawing.

### **WARNING: DRESS SAFELY.**

Make a list of all protective clothing and/or safety equipment recommended by the manufacturers of all items or equipment used in the installation. Follow all the safety practices and procedures outlined by each respective manufacturer.

## INSTALLATION AND OPERATIONAL PROCEDURES FOR BASCO "ES" HEAT EXCHANGERS

**Drain Piping** must be suitable for discharge to the atmosphere (if permissible), or into a vessel at lower pressure. Do not pipe to a common closed manifold.

**Fluid Pulsation and Mechanical Vibrations** to heat exchangers must be minimized in all installations. Install surge drums when the liquid is being delivered to the unit by a reciprocating pump, as the machine's vibrations can cause serious damage to the tubes.

**Safety Device Connections** are provided on shells when the tube side design pressure exceeds the shell side design pressure. To safeguard against failures or possible ruptures during operation, the shell must be protected with a safety relief valve or rupture disk of an approved type and set at the proper pressure. In the tube circuit, such devices should be placed in the inlet piping between the nearest valve and the unit. Proper sizing of the relief device is the responsibility of the buyer/owner.

**EXTERNAL BOLTED JOINTS** may require re-tightening in a uniform, diametrically staggered pattern, as illustrated below. Although all API heat transfer equipment is pressure tested before leaving our plants, normal relaxing of the gasketed joints may occur in the interval between testing and start-up.

DIA. - T.P.I.	TORQUE (FT.LBS.)	TORQUE STEPS
1/2-13	60	2
5/8-11	120	2
3/4-10	200	3
1-8	490	3
1 1/8-8	710	3
1 1/4-8	1000	3
1 1/2-8	1600	3
1 3/4-8	3000	4
2-8	4400	4

\* Contact factory for other types of gaskets. (See drawings or parts list for gasket information.)

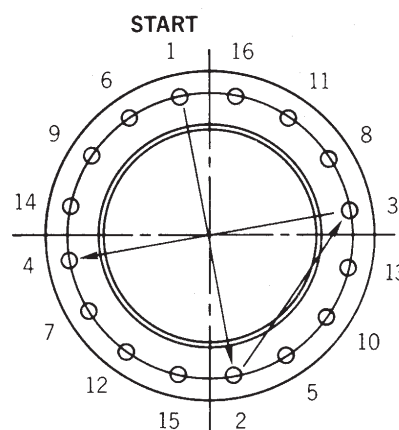

**BOLT TIGHTENING PROCEDURE**

## OPERATION

Operation Procedures must be strictly followed in start-up and shut-down sequences, especially in fixed tubesheet units where improper start-up or shut-down may cause leaking of tube-to-tubesheet and/or bolted flanged joints. Heat exchangers should not be subjected to abrupt temperature fluctuations. The hot fluid must not be introduced when the unit is cold, nor the cold fluid introduced when the unit is hot.

Equipment must not be operated at conditions that exceed those for which the unit was designed.

**CAUTION: Heat exchangers are pressure vessels. The stated operational pressures and temperatures should NOT be exceeded.**

### START-UP

1. Check the system for cleanliness to avoid plugging of tubes and pass partitions with refuse. Protective screens or strainers in piping to the heat exchanger are recommended.
2. Vent valves should be opened before fluid is admitted to any heat exchanger.
3. Check all flange bolting for tightness.
4. Start flow of fluids gradually, introducing the colder fluid first. When the system is completely filled and air vented, close vent valves.
5. When operating temperatures are reached, bolting and packed joints should be re-tightened to prevent leaks and gasket failures.
6. The heat exchanger should never be operated at pressures, temperatures and flows in excess of those specified on the nameplate and design specification sheet.

7. For heat exchangers used in steam service, provision must be made to drain accumulated condensate prior to start-up.

### THERMAL SHOCK

Extreme caution must be taken to avoid subjecting the heat exchanger to thermal shock, excessive pressures or temperatures. These conditions can impose stresses resulting in premature heat exchanger failure as well as, damage to other components in the system.

### SHUT-DOWN

Most heat exchangers with removable tube bundles may be shut-down by gradually reducing the flow of the hot medium and then the cold medium. Should it be necessary to stop the cold fluid first then the hot medium should be stopped at once. For a fixed bundle heat exchanger, both mediums should be stopped in such a manner to minimize the differential thermal expansion between shell and tubes. By-pass piping may be incorporated for this purpose.

# INSTALLATION AND OPERATIONAL PROCEDURES FOR BASCO "ES" HEAT EXCHANGERS

## MAINTENANCE

Typically, the failure of a heat exchanger to perform to specifications may be caused by one or more of the following factors: (1) excessive fouling, (2) air or gas binding resulting from improper piping installation or lack of suitable vents, (3) operating conditions differing from design conditions, (4) maldistribution of flow in the unit.

Inspection of Basco Heat Transfer equipment at regular intervals, as frequently as experience indicates, can identify potential problems before any significant damage occurs. The inspection should include an examination of both the interior and exterior of the unit.

Failure to keep all tubes clean can result in severe flow restrictions through some tubes which could cause damaging thermal stresses, resulting in leaking tube joints or structural damage to other components.

Temperatures and pressures of the fluid entering and leaving the equipment should be checked regularly to evaluate the function of the unit. For example, an increase in the pressure drop across the unit-with an accompanying decrease in the outlet temperature may indicate vapor or gas binding.

A slight sludge or scale coating on the tube interiors greatly reduces the heat transfer efficiency. Therefore, exchangers subject to fouling or scaling should be cleaned periodically. A marked increase in pressure drop and/or reduction in performance usually indicates cleaning is necessary. The unit should first be checked for air or vapor entrapment to confirm that this is not the cause for the reduction in performance. Since the cleaning effort increases rapidly as the scale thickness or deposit increases, the intervals between cleanings should be based on the plant's operating history.

*Disassembly* and removal of the bundle for visual inspection and cleaning is desirable. Regular inspection and cleaning are highly recommended when the fluids handled are fouling or highly corrosive and the bundle should be checked for excessive corrosion.

**CAUTION!:** Before disassembly the user must ensure that the unit has been completely shut down and depressurized, vented, drained, and neutralized and/or purged of hazardous material.

Care must be taken when "handling" the fouling material and the cleaning agent. Follow the chemical's "handling instructions" and wear all forms of eye, respiratory and body protection recommended.

### TESTING WITH BUNDLE INSTALLED:

If necessary to test tubes or tube joint integrity, the following procedure may be used:

- 1) Remove coolant headers at each end leaving the o-ring retainer in place. Provide a test ring to hold the gasketed joint of the stationary tubesheet to shell flange. This will provide access to both tubesheet faces. Fit suitable test covers to the shell side connections.
- 2) Pressurize the shell with shop air to the desired pressure, taking precautions not to exceed the test pressure shown on the nameplate. Blow excess coolant from inside of tubes and dry faces of tubesheets. Apply soap or leak check solution at tube ends.
- 3) If a leak exists at a rolled joint, the tube may be re-expanded using a conventional tapered pin roller.
- 4) If the leak is originating from the tube interior, it would indicate a leak through the tube wall. This type of cooler does not permit the removal and replacement of individual tubes. A leak of this nature will require the tube to be plugged at each end using a suitable tapered metal plug driven into the tube. Prior to plugging, either cut the tube or drill out one end. This will allow the tube to expand as needed.

## INSTALLATION AND OPERATIONAL PROCEDURES FOR BASCO "ES" HEAT EXCHANGERS

**Bundle pulling** - When the bundle is one-third removed, provide adequate support at the stationary tubesheet to keep the bundle level. A nylon sling also may be used around the bundle; however, care must be taken to prevent damage to the silicone seal strips and bundle casings.

**CAUTION!: When removing the tube bundle...**

- Do not exceed stated load capacities of any piece of equipment or tools used.
- Wear and/or follow all recommended protective clothing and other safety practices.

**Cleaning** of Basco Type ES heat exchangers is important to assure the equipment provides satisfactory performance. The equipment may be cleaned by either chemical or mechanical methods. The method selected must be the choice of the operator of the plant and will depend on the type of deposit and the facilities available in the plant. These are suggested methods:

The tubeside may be flushed with water to remove soft fouling, such as mud or sand. For hard scaled surfaces, rotary wire brushes or high pressure water blasting may be needed.

The fin side (gas) should be examined for contaminants and cleaned if fouled. Low-pressure steam or water lancing may be satisfactory. When hard deposits or scale exists, the bundle should be soaked in a sulfamic acid solution such as Oakite Drycid, but only as directed by the acid manufacturer. After cleaning, rinse and passivate the bundle assembly thoroughly.

The shell interior should be wiped clean or, if rusted, wire brushed or sandblasted. Repaint any areas of the shell interior where required.

Shown at right are the three most common type of tube to tube sheet joints in use with the BASCO Type ES heat exchangers.

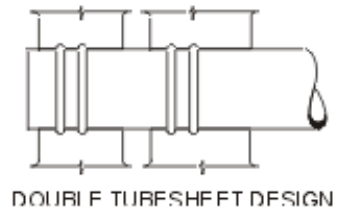
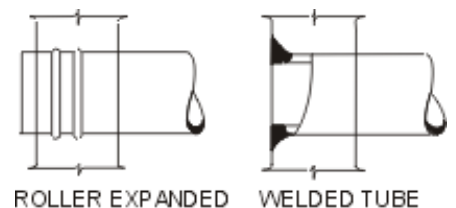
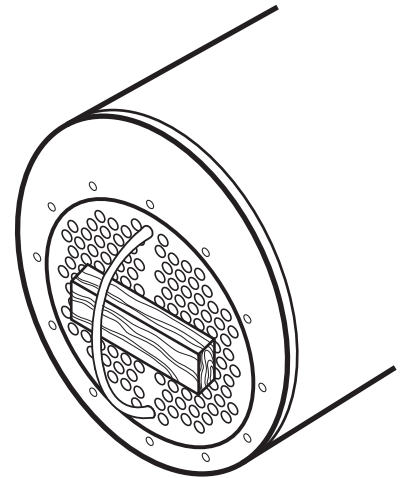
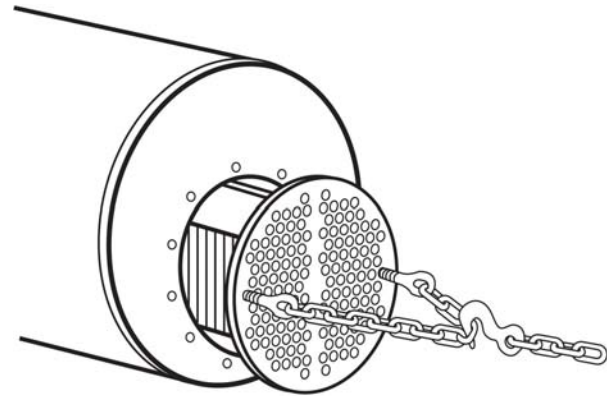

**CAUTION!: CLEANING PRECAUTIONS**

- Be careful to avoid damaging the tubes when mechanically cleaning a tube bundle.
- Cleaning compounds must be compatible with the metallurgy of the exchanger.

**DO NOT:**

- Introduce steam into an individual tube, as this can cause differential expansion stresses, with possible leakage at the tube joints.
- Introduce air into units handling volatile fluids.

**WARNING!** Chemical disposal of the substances used in and to clean the heat exchangers are **HAZARDOUS!** Follow all local, state and federal ordinances in the removal and disposal of these substances.

## INSTALLATION AND OPERATIONAL PROCEDURES FOR BASCO "ES" HEAT EXCHANGERS

Regular, scheduled cleaning is important to prevent excessive deposits in the tubes, since these deposits may result in plugged tubes. Resultant overheating may be followed by leakage of the expanded joints, or result in other damage. Fouled tubes result in reduced performance.

NOTE: Individual tubes can not be removed. The bundle will be rendered useless if tubes are removed. Leaking tubes must be plugged.

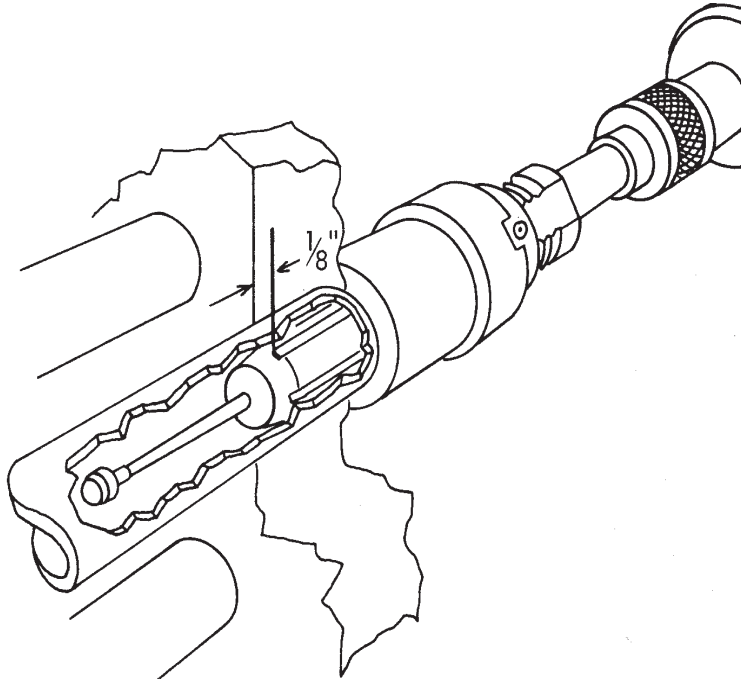

NOTE: When using a mechanical tube expander, set the depth control collar to assure at least 1/8" between the expansion roller end and the inside of the tubesheet.

**Gaskets** and gasket surfaces should be thoroughly cleaned and should be free of scratches and other defects. Gaskets should be properly positioned before attempting to retighten bolts. When a heat exchanger is dismantled for any cause, it must be reassembled with new gaskets. This will tend to prevent further leaks and/or damage to the gasket seating surfaces of the heat exchanger. Composition gaskets become dried out and brittle so that they do not always provide an effective seal when reused. Metal or metal jacketed gaskets, when compressed initially, conform to match their contact surfaces. In so doing they are work hardened. If reused they may provide an imperfect seal or result in deformation and damage to the gasket contact surfaces of the exchangers.

Bolted joints and flanges are designed for use with the particular type of gasket specified. Substitution of a gasket of different construction or improper dimensions may result in leakage and damage to gasket surfaces. Therefore, any gasket substitutions should be of compatible design.

Any leakage at a gasketed joint should be rectified and not permitted to persist as it may result in damage to the gasket surfaces.

Metal jacketed type gaskets are widely used. When these are used with a tongue and groove joint without a nubbin, the gasket should be installed so that the tongue bears on the seamless side of the gasket jacket. When a nubbin is used, the nubbin should bear on the seamless side.

**Spare and Replacement Parts** can be ordered directly from API Basco. When ordering parts, please provide the name of the part needed, as well as the heat exchanger serial number, type, and size from the nameplate on the unit.

## INSTALLATION AND OPERATIONAL PROCEDURES FOR BASCO "ES" HEAT EXCHANGERS

# API Heat Transfer

### REASSEMBLY:

- 1) Clean all gasket surfaces with rotary wire brushes.
- 2) Always use new gaskets. Refer to the parts list for correct part numbers. Silicone seals may be reused if they are not brittle or torn. If in doubt, replace the seals with new issue.
- 3) Install a new gasket on the shell flange at the stationary tubesheet end, using a suitable adhesive to hold the gasket in place during assembly. Apply liberal amounts of a suitable lubricant (PARKER O LUBE, liquid dishwashing liquid, etc.) to the bottom of the shell where it forms the sealing surface with the silicone rubber seal.
- 4) Apply liberal amounts of a suitable lubricant (PARKER O LUBE, liquid dishwashing liquid, etc.) to the upper seal. Lift the bundle with slings and insert it into the shell as far as the slings will allow. Block up the stationary tubesheet and re-sling to allow for complete insertion into the shell. Check the match marks for correct orientation of the bundle. Extreme care must be taken with the silicone rubber seals. If the seal strips are damaged or are not in their correct position, the result will be hot gas by-pass from the hot to cold side and the cooler performance will be reduced dramatically. Damaged seals must always be replaced.
- 5) When the bundle is in place and correctly oriented, the supply header can now be bolted in place, using a diametrically opposed tightening pattern. Torque to the recommended values in two or three steps.
- 6) After the supply header is completely tight, install the o-ring seal, packing gland and return header. As above the return header should be bolted using a diametrically opposed tightening pattern. Torque to the recommended values in two or three steps. The bolting of the packing gland should be initially torqued to about 8 ft lbs.

### START UP:

- 1) Remove any drain plugs from the shell side (gas).
- 2) Open vents on the supply header and fill the tubeside with coolant. Close the vents and circulate coolant for at least 15 to 20 minutes, checking for leaks at the gaskets.
- 3) Check all coolant side gaskets for leakage.
- 4) Observe the shell drains. If the gas side is not dripping coolant, the unit is ready for start up. Close the shell side drains.
- 5) Admit hot air to cooler. Allow the cooler to reach operating temperature. Examine the packing gland area for air leaks. If the packing gland is leaking, gradually increase the torque on the packing gland nuts until the leaks have stopped.

### Schematic of Typical Basco Type ES

This diagram shows the flow paths through a typical BASCO Type ES cooler.

Note the gas crosses the bundle only once. This is what allows the BASCO Type ES cooler to cool large amounts of gas with minimum pressure drop.

Shown here are the optional agglomerator plate and mesh pad.

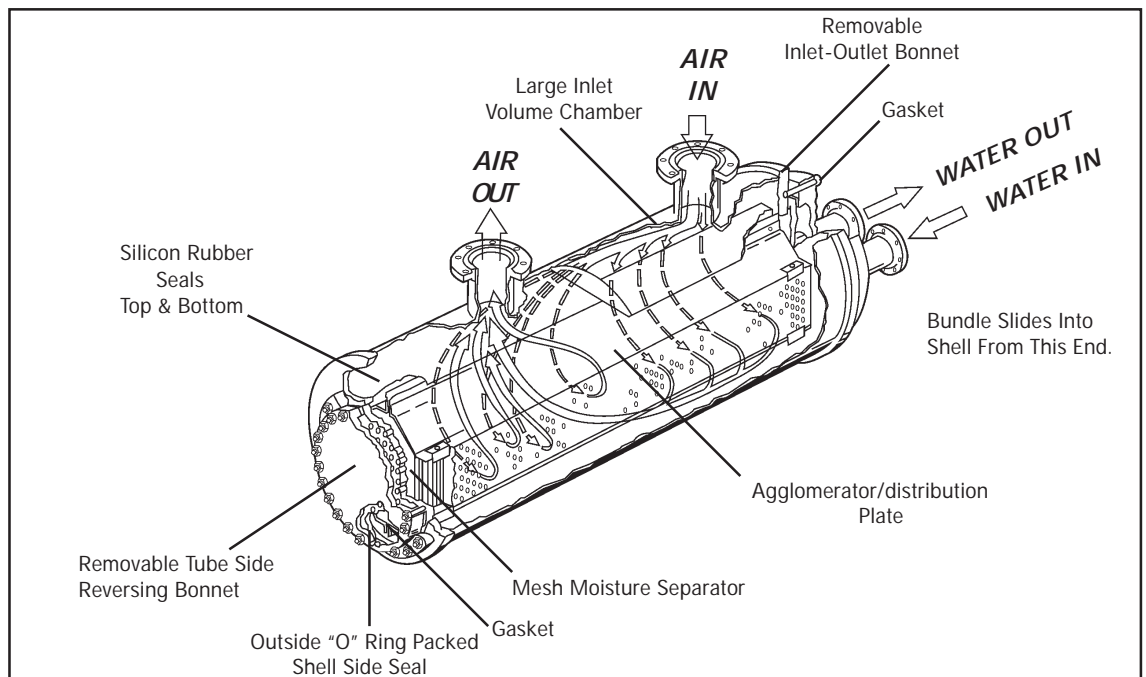

# API Heat Transfer

API Heat Transfer Inc.  
2777 Walden Avenue  
Buffalo, NY 14225  
(716) 684-6700

## Divisions:

### API Airtech ISO-9001 Certified

*Air Cooled Aluminum Heat Exchangers*

91 North Street • P.O. Box 68  
Arcade, New York 14009-0068  
(585) 496-5755 • Fax: (585) 496-5776

### API Basco ISO-9001 Certified

*Basco®/Whitlock® Shell & Tube Heat Exchangers*

2777 Walden Avenue  
Buffalo, New York 14225  
(716) 684-6700 • Fax: (716) 684-2129

### API Schmidt-Bretten Americas

*Plate Heat Exchangers and  
Thermal Process Systems*

2777 Walden Avenue  
Buffalo, New York 14225  
(716) 684-6700 • Fax: (716) 684-2129

### API Schmidt-Bretten GmbH & Co. KG

*ISO-9001 Certified*

*Plate Heat Exchangers and  
Thermal Process Systems*

Langenmorgen 4, D-75015 Bretten  
P.O. Box 1580, D-75005 Bretten, Germany  
7252/53-0 • Fax: 7252-53/200

### API Suzhou

*Air Cooled Aluminum Heat Exchangers,*

*Basco Shell & Tube Heat Exchangers*

156 Qingqiu Street, 3rd District  
Suzhou Industrial Park  
Suzhou, Jiangsu 215126  
China  
512-88168000 • Fax: 512-88168003

*Call your local API Sales Representative or  
API directly toll-free at 1-877-API HEAT.*

*Visit us at [www.apiheattransfer.com](http://www.apiheattransfer.com) or  
e-mail us at [sales@apiheattransfer.com](mailto:sales@apiheattransfer.com)*

## Other Products Available from API Heat Transfer

### OptiDesign®



Straight-tube, removable bundle exchangers made from standard components. Floating tube sheet for seal leak detection and easy maintenance. Diameters from 3" (7.62 cm) to 42" (106.68 cm). ASME, API, TEMA, ABS and other codes available.

### TEMA Shell and Tube



A wide variety of TEMA types are available using pre-engineered or custom designs in various sizes and materials. Shell diameters from 6" (15.24 cm) to 60" (152.4 cm), ASME, TEMA, API, ABS, TUV, ISPEL and other code constructions available.

### Pipeline Aftercoolers



Straight tube, counterflow aftercoolers designed to yield cool, dry compressed air. Available with or without accompanying moisture separators and constructed to a wide variety of design codes. Diameters from 6" (15.24 cm) to 42" (106.68 cm).

### Plate Heat Exchangers



Compact units provide excellent heat transfer and small size. Plates are pressed from stainless steel, titanium and other alloys. Gaskets of nitrile, EPDM, Viton®, compressed fiber and Teflon® are used. Gasket-free welded and brazed designs available.

### Type 500 Shell and Tube Heat Exchangers



General purpose exchangers designed to cool oil, compressed air and other industrial fluids. A variety of constructions, port configurations and materials are available. ASME and TEMA-C available. Diameters from 3" (7.62 cm) to 12" (30.48 cm).

### Brazed Plate Heat Exchangers

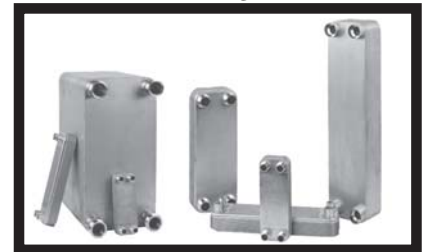

Off-the-shelf, standard units reflect the latest in plate heat exchanger technology for maximum performance and low cost. Ideal for OEM or aftermarket applications. Many models stocked and ready to ship. Models for process or refrigeration applications.

### Air-Cooled Heat Exchangers



High efficiency, brazed aluminum coolers for cooling a wide variety of liquids and gases with ambient air. Lightweight, yet rugged. Capable of cooling multiple fluids in single unit. Models can be supplied with cooling fan and a variety of drives.

### PCR



Designed specifically for air dryer OEM's, the all-aluminum brazed PCR combines a regenerative economizer with a refrigerant cooling section and a built-in moisture separator to provide the most compact, efficient 3-in-1 heat exchanger available. Capacities from 76 to 600 SCFM @ 100 psi with exiting RH below 25%.